

[9.5 P]^{PM} Plus

CLASSIC



Brought to you by:
American PM Crane Imports Inc.
Phone# (877) MY-PM-CRANE
(877) 697-6272
Or# (407) 246-1642
Dealer Inquiries Welcome:
Email: Corplnq@PMCranes.Com



[elevate to the highest power]^{pm}

[9.5 P] ^{PM}

New



BASIC PLUS

- _Distributore idraulico proporzionale D3000M
- _Proportional hydraulic control valve block D3000M
- _Distributeur hydraulique proportionnel D3000M
- _Proportionaler Steuerventilblock D3000M
- _Distribuidor hidráulico proporcional D3000M



Radiocomando multifunzione Scanreco/Hetronic.
Multifunction radio control Scanreco/Hetronic.
Radiocommande multifonctions Scanreco/Hetronic.
Funkfernsteuerung Scanreco/Hetronic.
Radiocontrol multifunción Scanreco/Hetronic.

New

ADVANCE PLUS

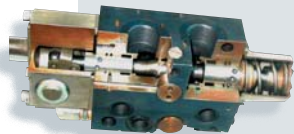

- _Distributore idraulico proporzionale compensato Hawe.
- _Hawe proportional hydraulic control valve block compensated.
- _Distributeur hydraulique proportionnel Hawe compensé.
- _Kompensierter proportionaler Steuerventilblock Hawe.
- _Distribuidor hidráulico proporcional Hawe compensado.

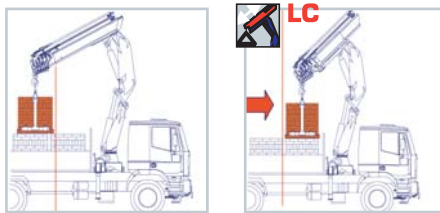

- Gru PM, versione LC, con primo braccio retraibile idraulicamente, agevola le movimentazioni ingombranti e gravose a corto raggio, ottimizzando anche le posizioni di carico sotto colonna.
- PM crane in LC version, with first hydraulic retractable boom, optimizes the load positioning close to the column, and makes easy the placement of heavy and bulky loads.
- La version LC, le premier bras rétractable hydrauliquement, facilite le chargement du matériel lourd et encombrant en augmentant la hauteur disponible sous crochet et la capacité de soulèvement près de la colonne.
- Die LC Ausführung, d.h. der hydraulisch einfahrbare erste Ausleger ermöglicht es sperrige Güter und große Lasten nah an der Säule zu heben. Dies wird auch durch die hohe Hakenfreiheit ermöglicht.
- En la versión LC, el primer brazo se recoge hidráulicamente, así que permite de elevar, mover y también colocar material pesado y de gran tamaño cerca de la columna.

EN12999

CONFORME ALLE NORME DI SICUREZZA EU
IN ACCORDANCE TO THE EU SAFETY STANDARDS
CONFORME AUX NORMES DE SECURITE EU
GEMÄß EU SICHERHEITSRICHTLINIEN
CONFORME CON LAS NORMAS DE SEGURIDAD EU

H1B3

CLASSE DI SOLLECITAZIONE A FATICA H1B3
FATIGUE-TESTED IN CLASS H1B3
ESSAIS EN FATIGUE EN CLASSE H1B3
ERMÜDUNGSTEST NACH KLASSE H1B3
COMPROBACION DEFATIGA EN LA CLASE H1B3

[3]

3 ANNI DI GARANZIA SULLE PARTI STRUTTURALI
3 YEARS OF WARRANTY ON THE STRUCTURAL PARTS
3 ANS DE GARANTIE SUR LES PARTIES STRUCTURELLES
3 JAHRE GARANTIE AUF STRUKTURBAUTEILE
3 AÑOS DE GARANTÍA EN LAS PARTES ESTRUCTURALES

[IIA]

DICHIARAZIONE DI CONFORMITÀ DEL PRODUTTORE
DECLARATION OF CONFORMITY OF THE MANUFACTURER
DECLARATION DE CONFORMITE DU PRODUCTEUR
KONFORMITÄTSEKLÄRUNG DES HERSTELLERS
DECLARACION DE CONFORMIDAD DEL PRODUCTOR

PQS

SISTEMA DI VERNICIATURA DI QUALITÀ CERTIFICATA
CERTIFIED PAINTING QUALITY SYSTEM
SYSTEME DE PEINTURE DE QUALITÉ CERTIFIÉE
ZERTIFIZIERTES QUALITÄTS-LACKIERSYSTEM
SISTEMA DE BARNIZADO DE CALIDAD CERTIFICADA

Tutte le gru PM sono coperte da polizza assicurativa internazionale per la responsabilità verso terzi.
All PM Cranes are covered by international insurance policy for civil liability third party.
Toutes les grues sont couvertes par une police d'assurance internationale de responsabilité civile envers tiers.
PM Krane sind durch eine internationale Haftpflichtversicherung gegen Dritte abgesichert.
Todas las grúas PM cuentan con una póliza de seguros internacional contra las responsabilidades civiles hacia terceros.

- Antenna a 1 e 2 sfilì su gru versione 2 sfilì
- Jib with 1 and 2 extensions on 2 extensions crane version
- Jib avec 1 et 2 extensions sur grue version 2 coulisses
- Jib mit 1 und 2 Ausschüben in der Kranversion mit 2 Ausschüben
- Jib con 1 y 2 extensiones en la grúa en versión 2 extensiones



EQUIPAGGIAMENTO DI SERIE - CONFIGURATION STANDARD EQUIPMENT - CONFIGURATION EQUIPEMENT STANDARD - SERIENMÄSSIG - EQUIPO DE SERIE



Radiocomando multifunzionale
Multifunction radio control
Radio commande multifonctions
Funkfernsteuerung
Radiomando multifunción



Cremafiliera
Slewing by rack
Rotation avec crémaillère
Zahnstangenschwenkwerk
Rotación con cremallera



Bracci stabilizzatori a sfilò manuale
Manual pull-out outrigger booms
Bras stabilisateurs avec extension manuelle
Manuelle Abstützungen
Brazos estabilizadores a salida manual



Uscita sequenziale sfilò bracci
Sequential extension booms' output
Sortie bras séquentiel
Anzahl der Ausschubzylinder
Salida secuencial de los brazos



Distributore idraulico proporzionale
Proportional hydraulic control valve block
Distributeur hydraulique proportionnel
Proportionaler Steuerventilblock
Distribuidor hidráulico proporcional



Dispositivo automatico sicurezze stabilizzatori inserite
Safety Kit for outriggers
Dispositif de sécurité stabilisateurs
Sicherheitskit für die Abstützungen
Kit de Seguridad para estabilizadores

OPTIONAL



Configurazione LC
LC configuration
Configuration LC
LC Ausführung
Configuración LC



Scambiatore di calore
Oil cooler
Refroidisseur
Ölkühler
Enfriador de aceite



Antenna
Fly-Jib
Jib
Jib
Jib



Verricello idraulico su gru
Hydraulic winch on crane
Treuil hydraulique sur la grue
Hydraulische Winde am Kran
Cabrestante hidráulico sobre la grúa



Canaline raccogli tubo
Activations with racks
Activations avec goutières
Schlauchketten für Zusatzgeräte
Bandejas



Bracci stabilizzatori a sfilò idraulico
Hydraulic pull-out outrigger booms
Bras stabilisateurs à extension hydraulique
Hydraulische Abstützungen
Brazos estabilizadores a salida hidráulica



Blocco Rotazione Elettroidraulico
Slewing limiter locking device electronic/hydraulic
Soupape d'arrêt rotation électronique/hydraulique
Elektronische Schwenkbereichsbegrenzung
Bloqueo rotación electrónico/hidráulico



Serbatoio
Oil tank
Réservoir
Öltank
Depósito de Aceite



Prolunghe manuali
Manual extensions
Rallonges manuelles
Mechanische Verlängerungen
Prolongas manuales



LMU: sistema di controllo CE per prolunghe meccaniche
LMU Device: control system for manual extensions
Dispo LMU: système de contrôle CE pour rallonges manuelles
LMU: CE Kontrollsystem für mechanische Verlängerungen
LMU: Sistema de control CE por prolongas manuales

- Disponibile fino a 4 sfilì idraulici
- Available up to 4 hydraulic extensions
- Disponible jusqu'à 4 extensions hydraulique
- Bis zu 4 hydraulische Ausschübe erhältlich
- Disponible hasta 4 extensiones hidráulicas

- Martinetti stabilizzatori rotanti manuali
- Manual tilting outriggers
- Vérins pivotant manuellement
- Manuell schwenkbare Abstützungen
- Brazos estabilizadores giratorios manuales

CLASSIC

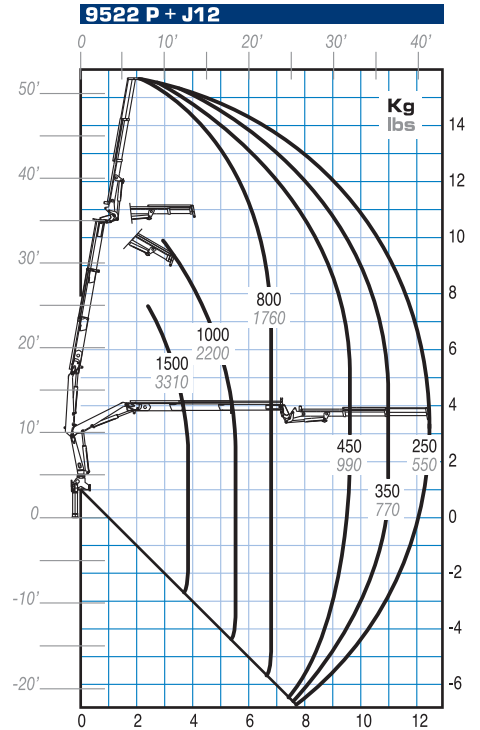
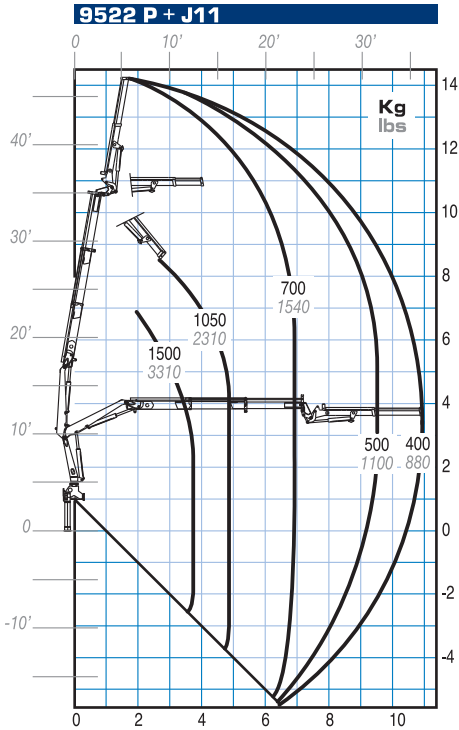
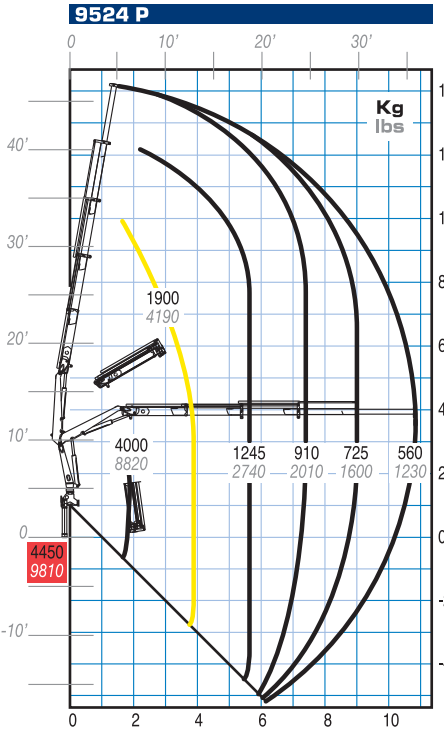
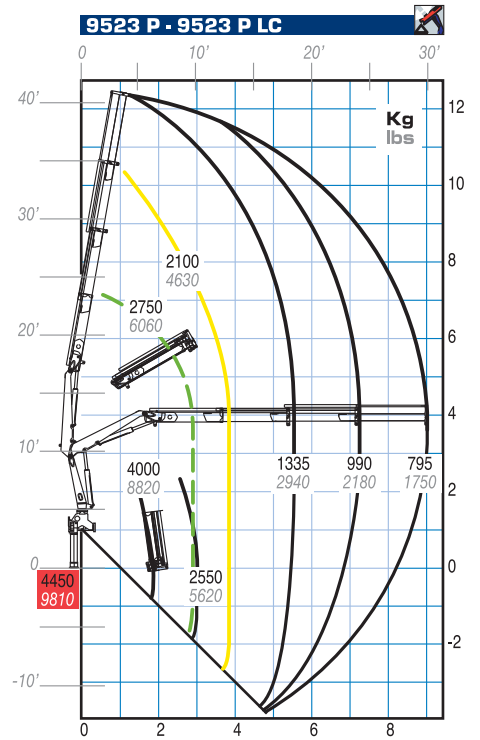
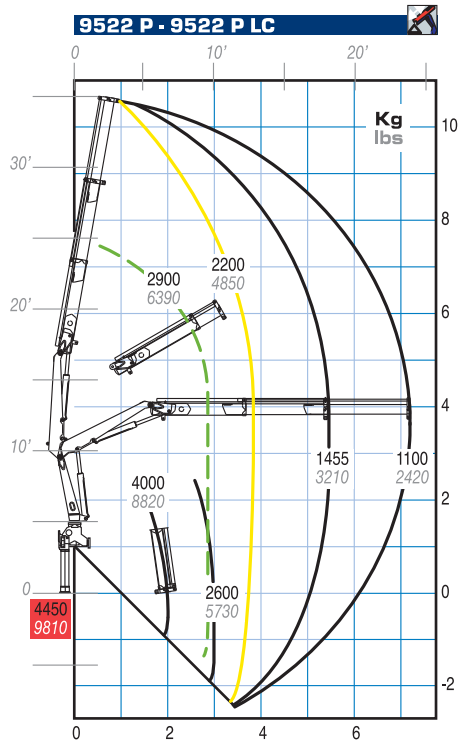
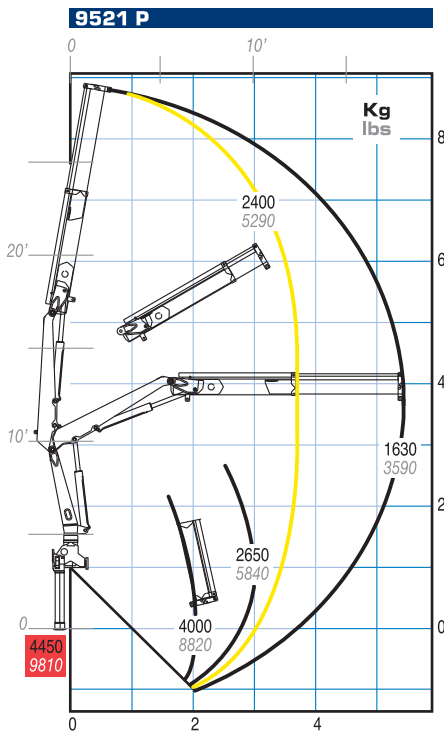

— Portata massima passante per l'orizzontale - Max. capacity from horizontal to vertical - Capacité maxi passant par l'horizontale - Max. Tragkraft von horizontal bis zu vertical - Máxima capacidad de la horizontal a la vertical
— Portata massima nominale al gancho fisso - Max. nominal capacity with fixed hook - Capacité maxi nominale au crochet fixe - Max. Nenntragkraft an der inneren Hakenbefestigung - Capacidad máxima en el gancho fijo
- - - Solo con grúa in versione LC - Only with LC version - Seulement avec version LC - Nur LC Version - Solo con grúa en versión LC



[9.5 P] PM

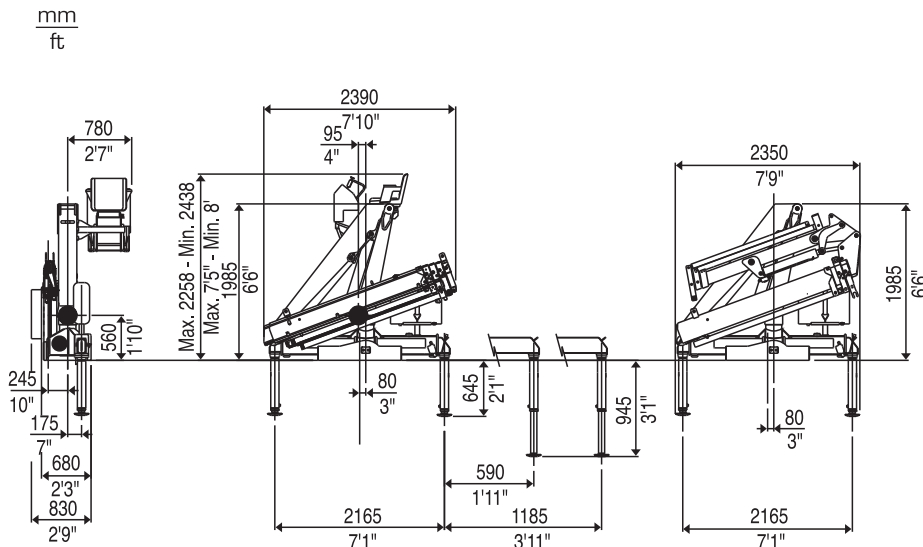

Abbinamento gru/veicolo Trucking crane combination Accouplement grue/véhicule Kran zusammen mit LKW Combinación grúa/camión

PTT/GVV	9.5P		
10,0 ton			2 stabilizzatori STD 2 outriggers STD 2 stabilisateurs STD 2 Abstützungen STD 2 gatos de apoyo STD
12,0 ton			
13,5 ton			
15,0 ton			2 stabilizzatori XL 2 outriggers XL 2 stabilisateurs XL 2 Abstützungen XL 2 gatos de apoyo XL
18,0 ton			
19,0 ton			
26,0 ton			4 stabilizzatori 4 outriggers 4 stabilisateurs 4 Abstützungen 4 gatos de apoyo
32,0 ton			

PTT: Peso totale a terra - G.V.W. - P.T.A.C.
LKW Gesamtgewicht - Peso total del vehículo

	9521 P	9522 P	9523 P	9524 P	9522 P +J11	9522 P +J12
Momento di sollevamento massimo - Maximum lifting moment - Moment de levage maxi - Max. Lastmoment - Momento de elevación máxima	tm	8,9	8,7	8,5	7,5	-
	ft. lbs	64370	62760	61160	54280	-
Sbraccio oleodinamico - Maximum hydraulic reach - Allongement hydraulique Hydraulische Reichweite, Standard - Alcance hidráulico orizzontale - horizontal - horizontal - horizontal verticale - vertical - vertical - vertikal - vertical	m	5,65	7,40	9,25	11,05	11,15
	ft	18'6"	24'3"	30'4"	36'3"	36'7"
	m	8,80	10,50	12,35	14,20	14,10
	ft	28'10"	34'5"	40'6"	46'7"	46'3"
Sbraccio con prolunghe - Maximum reach with manual extensions - Allongement avec rallonges manuelles - Reichweite, manuelle Verlängerungen - Alcance con prolongas manuales orizzontale - horizontal - horizontal - horizontal verticale - vertical - vertical - vertikal - vertical	m	-	13,00	13,00	13,00	14,10
	ft	-	42'8"	42'8"	42'8"	46'3"
	m	-	16,05	16,05	16,05	17,10
	ft	-	52'8"	52'8"	52'8"	56'1"
Impianto oleodinamico - Hydraulic system - Circuit hydraulique - Hydraulikanlage - Sistema hidráulico portata raccomandata - recommended oil flow - débit recommandé - empfohlene Fördermenge - caudal requerido pressione massima - rated pressure - pression max - Betriebsdruck - presión máxima capacità del serbatoio - tank capacity - capacité du réservoir - Tankinhalt - capacidad del depósito de aceite	l/min	20	20	20	20	20
	gals/min	5	5	5	5	5
	Mpa	27,5	27,5	27,5	27,5	27,5
	Psi	3990	3990	3990	3990	3990
	l	88	88	88	88	88
Gals	23	23	23	23	23	
Gruppo di rotazione - Slewing system - Rotation - Schwenksystem - Sistema de giro angolo di rotazione - slewing angle - angle de rotation - Schwenkbereich - ángulo de giro coppia di rotazione - slewing moment - couple de rotation - Schwenkmoment momento de giro pendenza massima di lavoro - max. working heel - devers max de travail - max Arbeitsneigung - inclinación máxima de trabajo	°	400	400	400	400	400
	kNm	14	14	14	14	14
	ft. lbs	10330	10330	10330	10330	10330
	%(°)	8,7(5)	8,7(5)	8,7(5)	8,7(5)	0
Peso della gru standard - Standard crane weight Poids de la grue standard - Eigengewicht - Peso de la grúa estandar Con serbatoio non rifornito - Empty oil tank - réservoir huile non garni - Leerer Öltank - depósito de aceite vacío Versione LC - LC version - LC version - LC Version - versión LC	kg	1054	1138	1192	1256	1365
	lbs	2325	2510	2630	2770	3010
	kg	-	1188	1252	-	-
	lbs	-	2620	2760	-	-

I dati tecnici possono essere aggiornati senza preavviso
Technical data can be revised without prior notice

Les données techniques peuvent être modifiées sans
preavis

Technische Änderungen vorbehalten
Reservado el derecho de modificaciones

Robert's Diesel Works Inc. 906 West gore St. Orlando, Fl. 32805

407 246-1597